



Job No. _____

Item No. _____

Quantity _____

AAA File No. 35-C111

SR42G Super Runner Gas Fryer

Basic Frying At Its Best Designed For All-Purpose Usage

Maximize your profits - combine more efficiency with more capacity in this all-purpose, affordable fryer.

Fry a wide variety of products - the full size 14" x 14" (35 x 35 cm) fry area easily accommodates items from french fries to large size menu selections.

Make the most of your energy dollars with our exclusive Thermo-Tube design. The heating tubes are surrounded by oil, and heat absorption is maximized with controlled flow tube diffusers. The energy is forced into the oil with less going unused up the vent. 1.25" (3.175 cm) drain valve makes cleaning fast and easy.

- Quick heat-up time relative to gas consumption.
- Low idle cost per hour during slow periods.
- Low gas consumption per load of product cooked.

Minimize costly oil usage - utilizes only 35-43 lbs. (20-25 L) of oil for optimum cooking efficiency. Plus, Dean's cool zone design reduces wasteful oil deterioration by trapping debris under the cooking area, preventing carbonization of particles and oil contamination.

Assure rapid recovery - Dean's accurate mechanical thermostat eliminates time lost in waiting between loads and requires no electrical hookup.

Invest in a product built to last - Dean fryers achieve long and dependable life through simplicity of design -- durable stainless steel diffusers and rugged cast iron burners keep maintenance to a minimum. Shipped standard with stainless steel front, door, and aluminized sides.



SR42G gas fryer standard with 105,000 BTU (26,481 kcal) (30.8 kW) burners and 35-43 lbs. (20-25 L) oil capacity.



14501 South Broadway, Gardena, CA 90248, USA • Telephone: 310/353-5000 • Toll Free: 800/995-1210 • FAX: 310/327-3343
<http://www.dean.welbilt.com>

Printed in U.S.A. 06/00

SR42G

Super Runner

Gas Fryer

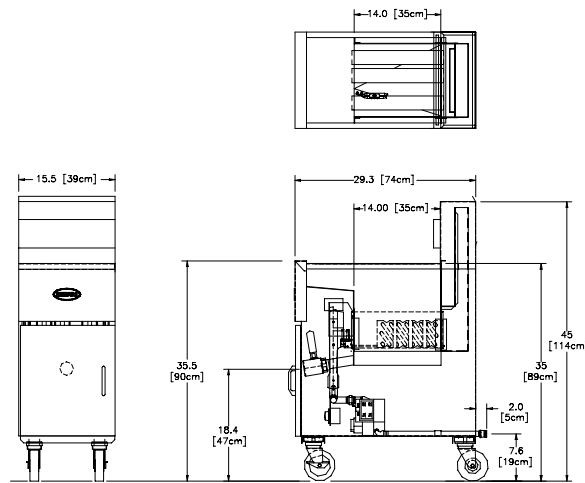

SPECIFICATIONS

Min./Max. Oil Capacity	Size (cm)				Drain Valve (cm)	Drain Valve Height (cm)	No. of Tubes	Frying Area (cm)	Shipping lbs./cu.ft. (kg/m ³)
	Width	Depth	Overall Height	Work Height					
35-43 lbs. (20-25 L)	15.50" (39)	29.25" (74)	45" (114)	35" (89)	1.25" (3.175)	18.4" (47)	3	14" x 14" (35 x 35)	150 lbs./15 (68/0,42)

POWER REQUIREMENTS

Natural or LP Gas Input Rating	Gas Connection	Electrical Requirement
105,000 BTU/hr. (26,481kcal) (30.8 kW)	3/4" N.P.T. regulator not required	NONE

SHORT FORM SPECIFICATIONS

Shall be DEAN free-standing cool zone deep fat fryer, Model SR42G. Only 15.50" (39 cm) wide, 35-43# (20-25 L) oil capacity, requiring 105,000 BTU (26,481 kcal) (30.8 kW) natural or LP gas input (3/4" N.P.T. connection) and mechanical controls.

ORDERING DATA

Please specify:
Natural or propane gas
Altitude -- if above 2000 ft. (610 m)

DEAN, whose policy is one of constant improvement, reserves the right to amend specifications without prior notice.

STANDARD FEATURES

- Stainless steel fry vessel
- Stainless steel front and door, aluminized sides
- Basket hanger and two fry baskets
5.62" x 5.62" x 13.25" (14 x 14 x 34 cm) insulated handles
- Cool zone fry vessel construction
- Millivolt pilot system - requires no electrical hookup
- 6" (15 cm) adjustable steel legs

OPTIONS

- Stainless steel sides
- Casters -- set of 4
- See Dean Price List for optional accessories

